

# JSJ JODEIT GMBH SPECIALITY GLASS

MELTING FURNACES, CONDITIONING, SYSTEMS AND COMPONENTS

**JSJ JODEIT** 

A MEMBER OF **HORN**®

*innovation*

ENGINEERED IN GERMANY

# JSJ SPECIALITY GLASS

---

Since its foundation in 1991, JSJ Jodeit GmbH has developed into a leading and globally renowned supplier of systems for the production of speciality glass.

The core competence lies in the development, planning and realisation of melting furnaces, systems and components for the production of high-quality speciality glasses.

Depending on the type of glass, the melting furnaces are realised in different geometric designs with bottom, sidewall and top electrodes made of molybdenum or tungsten.

From concept development to commissioning, JSJ manages projects of varying sizes, ensuring adherence to timelines, high quality standards and cost-efficient completion.

JSJ's state-of-the-art All Electric Furnace (AEF) range from 5 t/d - 200 t/d.

## **JSJ Jodeit furnaces impress by:**

- Compact design
- High specific melting capacity
- High glass quality
- Simple operation
- Comparable high flexibility
- Minimal air pollution
- Low energy consumption



For the future, JSJ expects electric melting as one of the highest growth areas in glass melting. Not only for technical glass, but also for container and float glass, increasing fuel costs and economical use of fuel, reduction of dust, CO<sub>2</sub> and NOx-emissions, will become more and more important.

JSJ understands these current trends and is working on solutions for electric glass melting that result in increased productivity and energy-efficient melting processes at the same time.

## **JSJ Jodeit has reached a world-wide reputation for technical excellence:**

- High glass quality
- Safe and smooth operation
- Comparatively low investment costs
- Significant energy savings
- Low dust and NOx-emission
- Advanced furnace lifetime
- Minimized CO<sub>2</sub> emission

## **JSJ Jodeit Portfolio:**

- All Electric Furnaces (AEF)
- Oxyfuel Furnaces
- Electric heated glass conditioning systems
- Systems and Components
  - o Special top electrode holder for forehearths
  - o Special electrode holder for sidewall and bottom installation
  - o Electrodes for AEF
  - o Drainage Systems

# ALL ELECTRIC FURNACES (AEF)

The All Electric Furnace (AEF) is heated entirely with electric current and operated as a cold top furnace. This eliminates hot exhaust gases that could be contaminated with evaporation products of the molten glass.

All Electric Furnaces are used for many types of glass, especially for glass types that tend to evaporate, e.g. borosilicate glasses, opal glasses.

There are increasing applications for soda lime glasses when unacceptable emissions at the site or the use of renewable energies are driving the decision.

The geometric shape of the basin can be square, dodecagonal or rectangular.

The electrodes are installed as top, bottom or sidewall electrodes which deliver the melting energy into the melt. The melt is completely covered by a mix of batch and cullet. This allows operation with a cold top furnace and reduces energy losses of the melt.

## TECHNICAL DATA

- **Glass types:**
  - Borosilicate glass
  - Opal glass
  - Fibre glass
  - Soda lime glass
- **Temperature of the glass: < 1620°C**
- **Pull rate: < 200 t/d**
- **Cullet ratio: 0 ... 60%  
(depending on glass type)**

## FEATURES

- **Melting of demanding glass types with lowest emissions**
- **Comparatively low space requirement**
- **Minimal CO<sub>2</sub> emissions**



# OXYFUEL FURNACES

---

The melting furnace heated with oxygen and gas is preferably used for melting demanding types of glass for high melting temperatures (e.g. borosilicate glasses, TFT glasses).

By arranging the burners transversely to the furnace axis, a temperature profile can be set for best melting and refining of the molten glass.

A barrier is installed in the basin to facilitate the local separation of the melting process from the refining process.

Depending on the application, additional electrical heating of the melt is provided to support the melting and refining process.

The combination of technological components ensures high energy efficiency and the highest quality standards for the glass melt.

## TECHNICAL DATA

- **Glass types:**
  - Borosilicate glass
  - TFT-glass
  - Alumo-Silicate glass
- **Temperature of the glass: < 1.650°C**
- **Pull rate: 6 ... 50 t/d**
- **Cullet ratio: 20 ... 60%**

## FEATURES

- **Highest glass quality**
- **High energy efficiency**
- **Long service life**





# CONDITIONING

## ELECTRICALLY HEATED FOREHEARTH

Electrically heated forehearth and distributors with covered glass bath surface are particularly suitable for demanding glass types that tend to evaporate volatile components.

JSJ distributors and forehearths are designed as rectangular cross-section channels for the operation of small and medium pull rate. The distributors are connected upstream of the forehearths. The forehearths provide subsequent forming processes with thermally and chemically homogeneous glass melt while maintaining the required, high temperature stability.

Special water-cooled molybdenum electrodes are installed through the superstructure of the distributors and forehearths. The necessary energy is supplied via these electrodes by passing current directly through the melt. The electrodes are connected in several heating circuits that are operated in a temperature-controlled manner.

Drains installed in the bottom ensure the removal of corrosion products of the refractory material and thus a very good chemical homogeneity.

If required, specially designed stirrer systems are provided which additionally ensure thermal and chemical homogeneity.

Radiometric glass level measurements can be installed alongside the superstructure of the distributor or forehearths if required. Special start-up electrodes are installed at the bottom of the distributors and forehearths.

## TECHNICAL DATA

- **Glass types:**
  - Borosilicate glass
  - Opal glass
  - Soda lime glass
- **Glass temperature: < 1.450°C**
- **Temperature homogeneity at the equalizing section:  $\leq \pm 3K$**
- **Pull rate: 5 ... 30 t/d**
- **Forehearth length: 3.5 ... 4.5 m**

## FEATURES

- **No evaporation of volatile components**
- **Perfect glass quality**

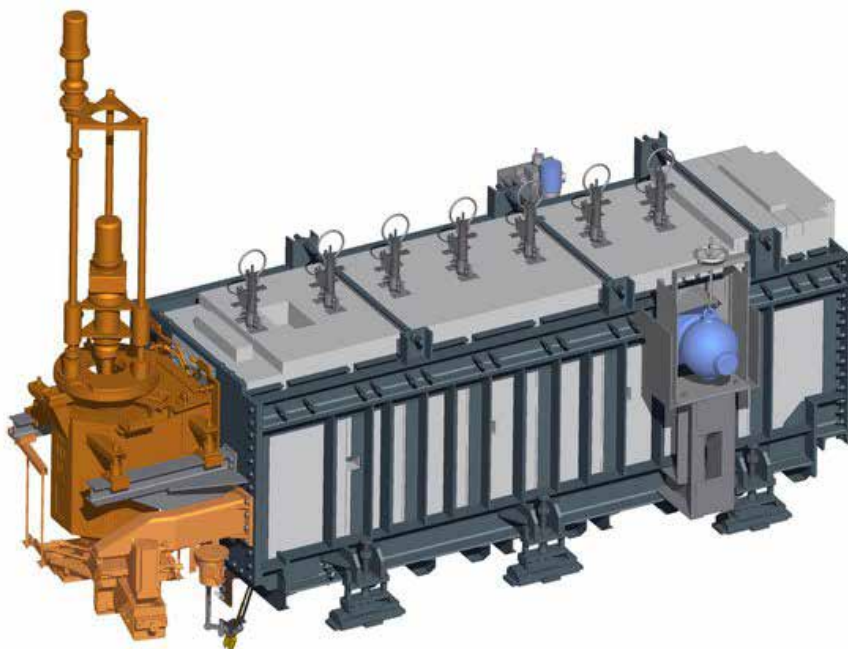

# TOP ELECTRODE - TYPE: FOREHEARTH

The top electrode forehearth is a proven tool for direct energy input into feeders and forehearths with a covered glass surface.

It consists of a media connection part, a glass-coated water-cooled connection piece and a molybdenum electrode. They are only installed vertically from above in the forehearth.

The immersion depth depends on the application. For energy input, electric current is conducted directly via the electrode through the molten glass to a counter electrode.

## FEATURES

- **Easy handling**
- **Firmly established in electrical heating of speciality glasses**
- **Produces very good temperature distribution in the melt**
- **Long service life**

## TECHNICAL DATA

- **Nominal diameter of the molybdenum electrode: 50 mm**
- **Electrical connection values**
  - o Voltage upon customer request
  - o Electrode surface load in normal operation  $< 0.5 \text{ A/cm}^2$
- **Cooling water**
  - o Amount  $< 1.2 \text{ m}^3/\text{h}$
  - o Pressure loss  $< 1.0 \text{ bar}$
  - o Cooling capacity  $< 3 \text{ kW}$

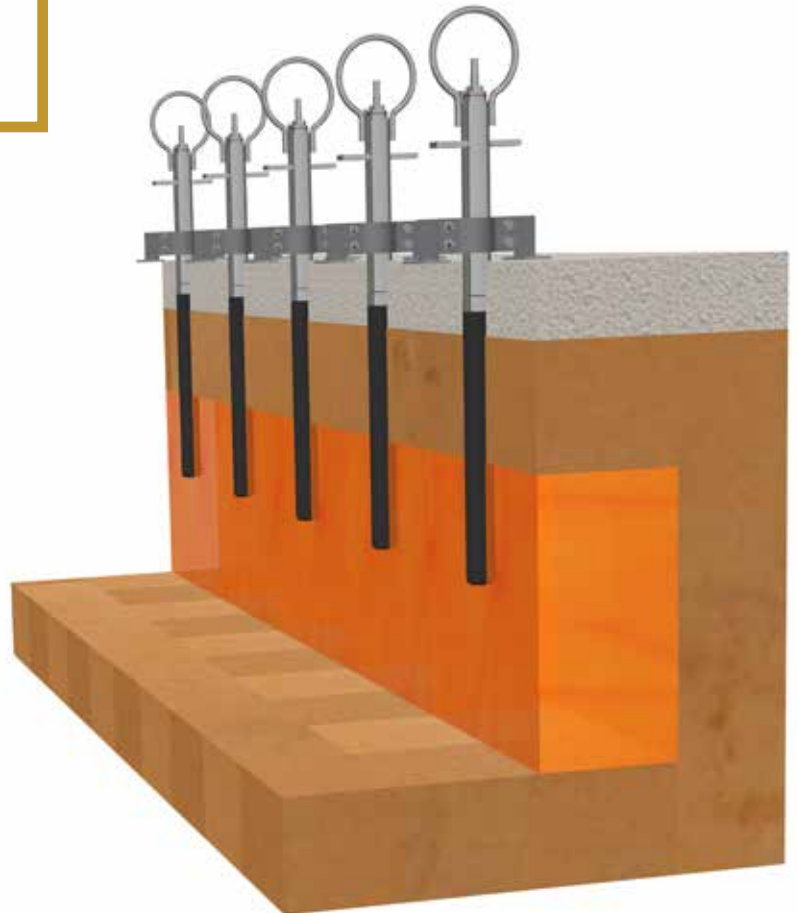

# ELECTRODE HOLDER

Electrode holders serve to cool, guide and hold molybdenum electrodes installed in them. They thus protect the electrode from corrosion by the molten glass and from oxidation by ambient oxygen.

Electrode holders are designed for horizontal or vertical installation in the glass contact material of glass melting tanks and forehearths.

They consist of the water-cooled holder tube, a fixing for the electrode and a holder for electrically insulated attachment to the furnace steel. The holder tube is designed for different lengths depending on the refractory structure.

They are electrically insulated and fixed to the furnace steel so that electrical power can be supplied to the glass melt by the installed molybdenum electrodes.

## FEATURES

- **Small outer diameter of the holder**
- **Long service life due to reliable cooling**

## TECHNICAL DATA

### • Electrode holder

- o Length of the holder tube: 320 / 370 / 600 mm
- o Installation position: horizontal / vertical
- o Max. operating voltage: < 600 V AC

### • Electrodes with nominal diameter 50 mm

- o Type 50
  - o Cooling water amount < 1 m<sup>3</sup>/h
  - o Cooling water - pressure loss < 0.6 bar
  - o Cooling capacity < 6 kW

### • Electrodes with nominal diameter 80 mm

- o Type 80
  - o Cooling water amount < 1 m<sup>3</sup>/h
  - o Cooling water - pressure loss < 0.8 bar
  - o Cooling capacity < 10 kW

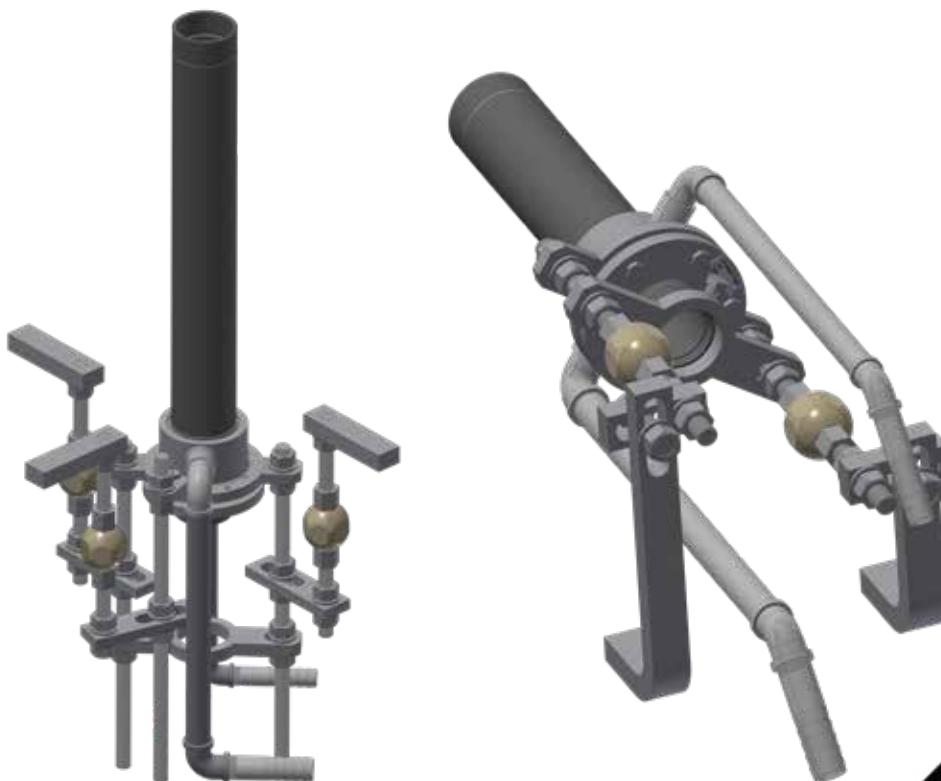

# TOP ELECTRODE - TYPE: FURNACE

The top electrode is used to heat glass melts from above through a cold batch layer. It is usually used to power the All Electric Furnaces (AEF).

The electrodes consist of the water-cooled holder, the water-cooled molybdenum part and a molybdenum electrode extension.

They are mounted on a swivel device which is used for the electrically insulated holder and for swivelling the electrodes in and out.

## FEATURES

- **Easy handling**
- **Firmly established in electrical heating of speciality glass melts**
- **Long service life**

## TECHNICAL DATA

- **Temperature of glass bath: max. 1620 °C**
- **Nominal diameter of molybdenum electrodes: 80 mm**
- **Connection requirements:**
  - o Max. operating voltage < 600V AC
  - o Electrode surface load in normal operation < 1 A/cm<sup>2</sup>
  - o Cooling water
    - o Quantity < 1.5 m<sup>3</sup>/h
    - o Pressure loss < 5.0 bar
    - o Cooling capacity < 15 kW

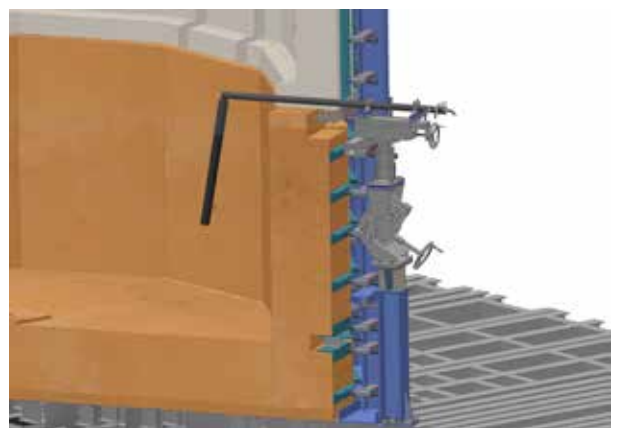
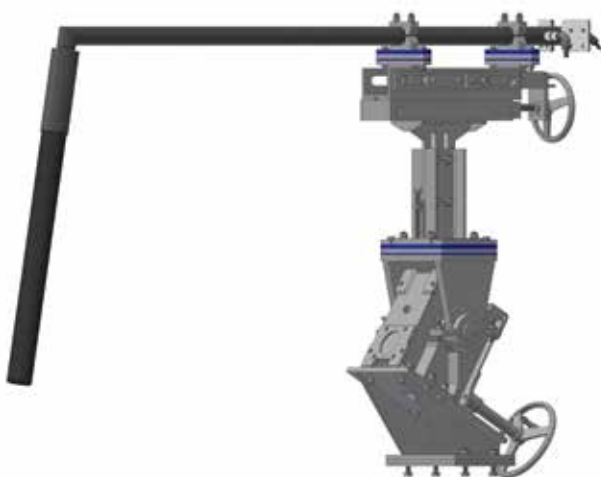



# DRAINAGE TYPE MO DISK

The drainage system type Molybdenum is designed for the drain of bottom glass from melting furnaces and forehearth or of condensates from flue gas ducts. It is designed for periodic operation.

The drain consists of a water-cooled housing and a head with a special arrangement of heat-resistant material. The head contains a plate electrode made of molybdenum.

This head is both the drain nozzle and the electrode. An exchangeable attachment nozzle is adapted to it. Depending on the type of glass and the temperature, the attachment nozzle is adapted to the desired working range of the pull rate.

The drain is pressed by the housing against a hole in the bottom block or in the flue gas duct.

It is designed with direct electrical heating and is operated with power control. For this purpose, current is conducted from the drain to a counter-electrode in the glass.

Furthermore, a gas-air burner with flame monitoring is installed for the start-up of the drainage.

The drainage system type Molybdenum is available as an integrated part of a complete plant or as a stand-alone system. As the drainage is normally integrated into a complete plant, the counter electrode is not part of the standard scope of delivery.

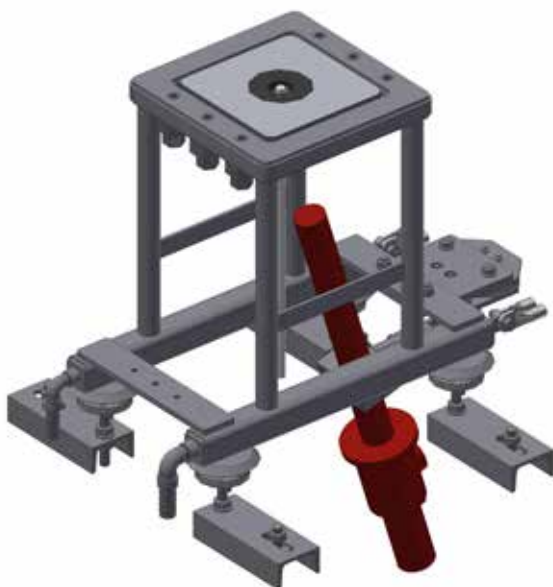

## TECHNICAL DATA

- **Operation mode: non-continuous**
- **Temperature of the glass melt: max. 1300°C**
- **Pull rate: nominal 1.0 ... 1.5 t/d**
- **Connection requirements:**
  - o Electric energy: 3ph/N/PE, 400V, 50Hz, < 25kVA
- **Cooling water Drainage**
  - o Amount < 1.1 m<sup>3</sup>/h
  - o Pressure loss < 1.0 bar
  - o Cooling capacity < 3 kW
- **Burner heating (Gas-air)**
  - o Quantity of gas (H<sub>u</sub> ~ 10 kWh/m<sup>3</sup>) < 4 m<sup>3</sup>/h

## FEATURES

- **Non-continuous operation**
- **Pull rate adaptable to different operating conditions**
- **Easy start of the drain after standstill**

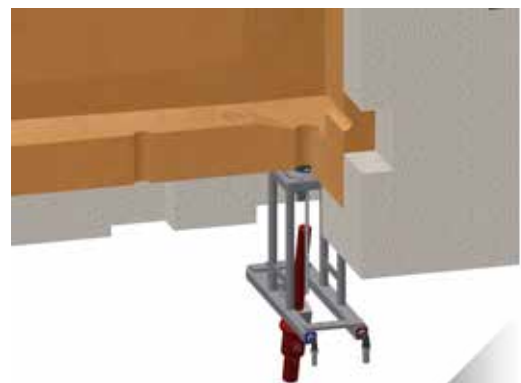

# DRAINAGE TYPE PT-DOUBLE TUBE

The Pt-drainage type double tube is intended for the drainage of glass from furnaces and forehearth in continuous operation. This drainage is recommended when viscous corrosion products of the refractory material that tend to crystallise sink to the bottom and cause defects in the product glass. The melt enriched with corrosion products can be removed with this drainage.

The drainage consists of a platinum tube which is installed at the bottom of the refractory and extends through the brick to the inner edge. An exchangeable attachment nozzle can be installed on the platinum tube. Depending on the type of glass and the temperature, the attachment nozzle is adapted to the desired working range of the pull rate.

The platinum tube is directly electrically heated and temperature-controlled. No counter-electrode is necessary.

For start-up and flow control, a burner heating or an inductively heated outlet nozzle is additionally installed.

The Pt-drainage type double tube is available as a stand-alone system or as an integrated component of a complete plant.

## FEATURES

- **Continuous temperature-controlled operation**
- **Stable pull rate**
- **Pull rate adaptable to different operating conditions**
- **Easy start of the drain after standstill**



## TECHNICAL DATA

- **Operation mode: continuous**
- **Temperature of the glass melt: max. 1.600°C**
- **Pull rate: nominal 1.0...1.5 t/d**
- **Connection requirements:**
  - o Electric energy:  
3ph/N/PE, 400V, 50Hz, < 15kVA
- **Cooling water Drainage**
  - o Amount < 0.6 m<sup>3</sup>/h
  - o Pressure loss < 0.6 bar
  - o Cooling capacity < 4 kW
- **Cooling water induction heating**
  - o Amount < 0.24 m<sup>3</sup>/h
  - o Pressure loss < 4 - 6 bar
- **Compressed air (if required)**
  - o Quantity acc. to ISO 8573-1, class 3  
30 m<sup>3</sup>/h
  - o Pre-pressure < 6 bar

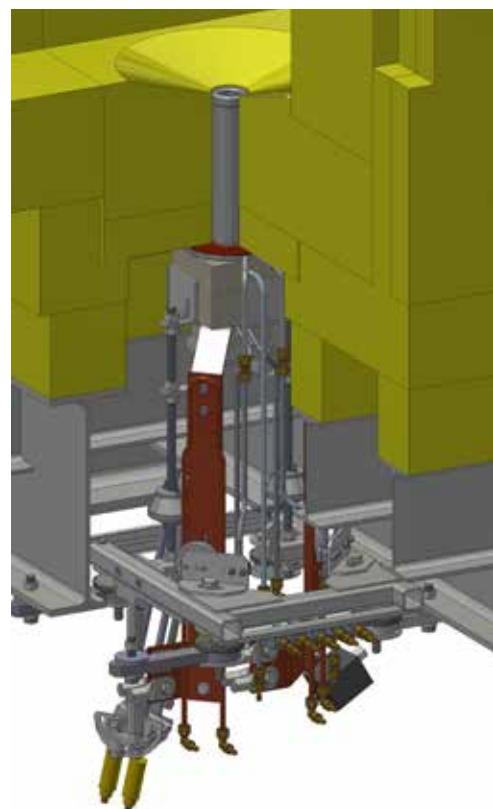

# DRAINAGE TYPE PT-CONE

The Pt-drainage type cone is intended for the drainage of glass from forehearths in continuous operation. This drainage is recommended when viscous corrosion products of the refractory material that tend to crystallise sink to the bottom and cause defects in the product glass.

The drainage is pressed directly against the outlet opening in the bottom brick.

The drainage consists of a platinum tube which can be fitted with a replaceable nozzle insert. Depending on the type of glass and the temperature, the attachment nozzle is dimensioned for the desired working range of the pull rate.

The platinum tube is directly electrically heated and temperature-controlled. No counter electrode is necessary.

For starting and for continuous operation, a burner heating with flame monitoring is additionally installed. The Pt-drain type cone is available as a stand-alone system or as an integrated part of a complete system.

## TECHNICAL DATA

- **Operation mode: continuous**
- **Temperature of the glass melt: max. 1500°C**
- **Pull rate: 0.5 ... 2 t/d**
- **Connection requirements:**
  - Electric energy: 3ph/N/PE, 400V, 50Hz, < 10kVA
- **Cooling water Drainage**
  - Amount < 0.6 m<sup>3</sup>/h
  - Pressure loss < 0.6 bar
  - Cooling capacity < 4 kW
- **Burner heating (Gas-air)**
  - Quantity of gas ( $H_u \sim 10 \text{ kWh/m}^3$ ) < 2 m<sup>3</sup>/h

## FEATURES

- **Continuous temperature-controlled operation**
- **Stable pull rate**
- **Pull rate adaptable to different operating conditions**

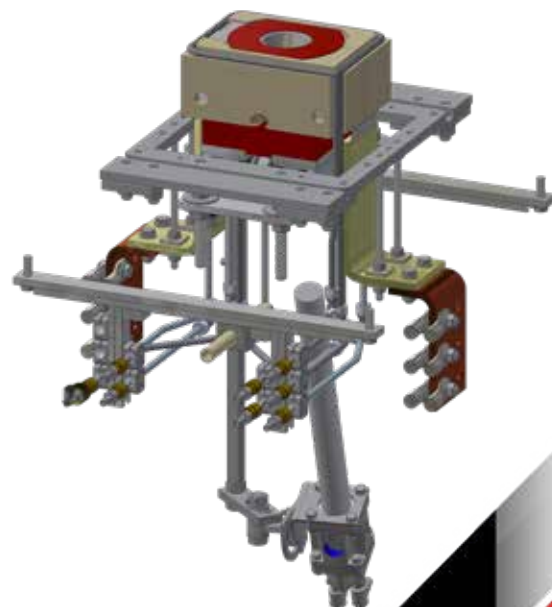
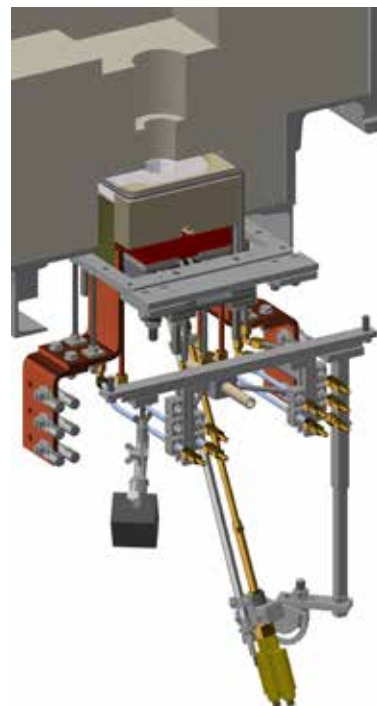

LET'S GO FULL CIRCLE. [WWW.HORNGLOSS.COM](http://WWW.HORNGLOSS.COM)

The key to HORN®'s extensive expertise in all fields of glass melting technology is the profound understanding of each detail within the entire process, making HORN® the specialist for technological progress and innovation for each aspect of a glass plant. In addition to its knowhow about individual elements such as furnaces, HORN® has expanded its services to become a one-stop supplier for turn-key plants. From initial planning to full operation - HORN® stands by you all the way.



**PLANNING +  
ENGINEERING**



**MANUFACTURING**



**SERVICE /  
INSTALLATION +  
SUPPORT**



**LET'S GO  
FULL CIRCLE.**

**JSJ JODEIT** 

A MEMBER OF **HORN®**

JSJ JODEIT GMBH  
A MEMBER OF HORN® GLASS INDUSTRIES AG  
BERGSTRASSE 2  
D-95703 PLÖSSBERG/GERMANY

TEL.: +49 9636 / 9204-0  
FAX: +49 9636 / 9204-10

[WWW.HORNGLOSS.COM/JSJSPECIALITYGLASS](http://WWW.HORNGLOSS.COM/JSJSPECIALITYGLASS) 08/2022